



SHINGARE  
INDUSTRIES PVT LTD

SHINGARE™  
INDUSTRIES PVT LTD

**BHARTIYA**

**TUBE TOOLS**

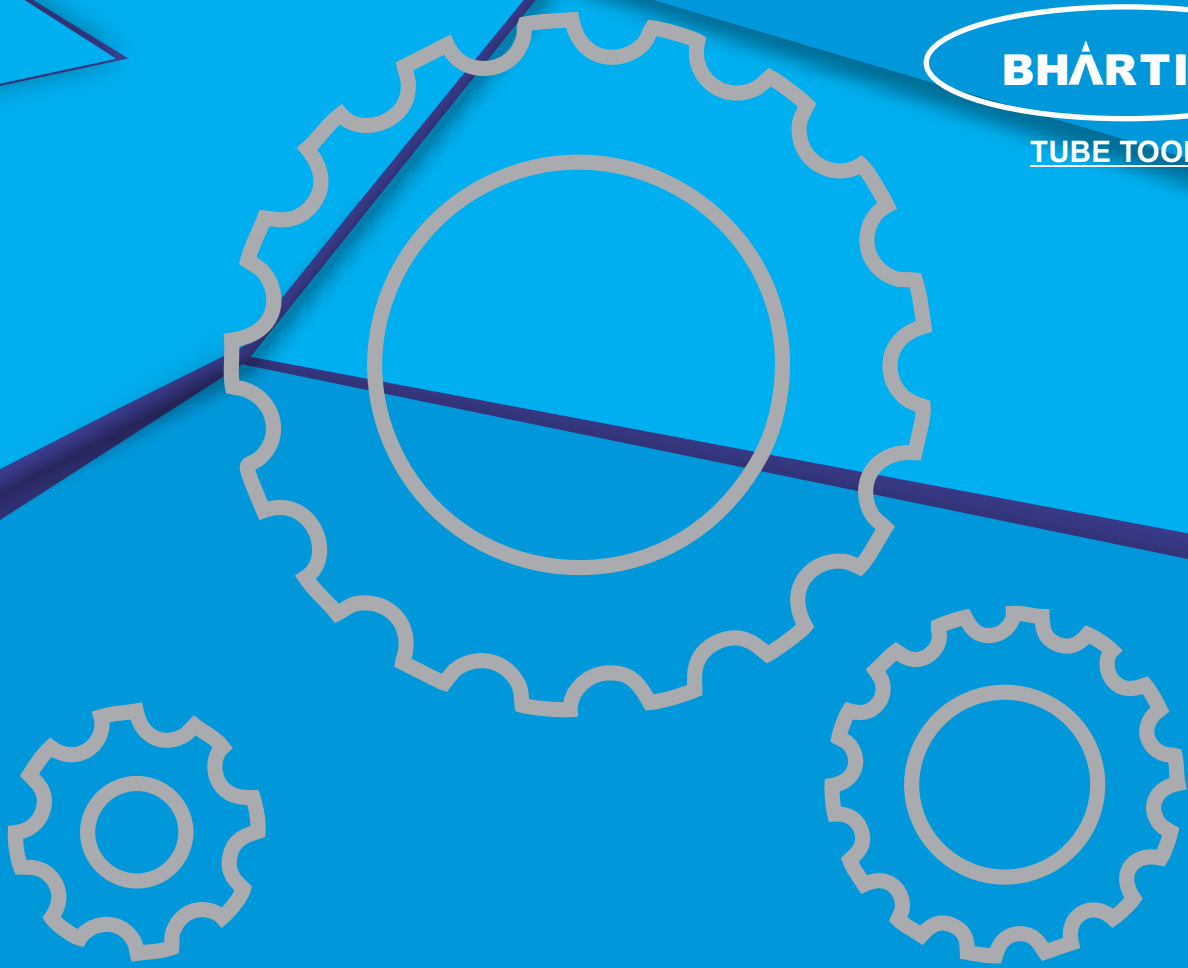

# HYDRAULIC TORQUE WRENCHES



**SHINGARE**  
INDUSTRIES PVT LTD

# LOW PROFILE HYDRAULIC TORQUE WRENCH



TUBE TOOLS

SXD series is the professional Low profile hydraulic torque wrench which SHINGARE extends in international market. Compared with the square drive hydraulic torque wrench, this series work directly on the nuts, and its body suits well in narrow space. SHINGARE covers the nuts from S19 to S175. To fulfill all different working situations, the user can just replace the hexagon cassette because the hexagon cassette is changeable, or add the reducer. SHINGARE provides a after-sales service all over the world, and already got the approved by TUV certificate.

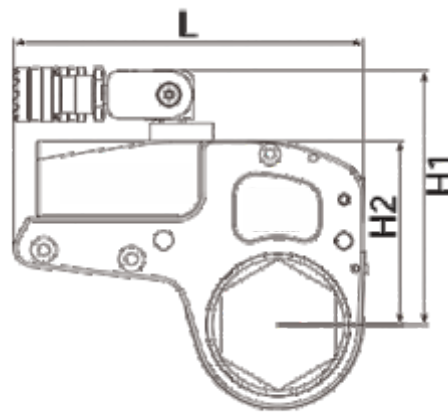

## SELECTION CHART

Model	Torque (N.M)	Nut Sizes (MM)	Power Head Weight Kg	Work Head Weight (kg)	Size			
					L1	H1	H2	W
SXD-2A	225-2255	19-55	0.9	1.5	186	132	95	32
	233-2338	60	0.9	1.5	186	135	98	32
SXD-4A	520-5208	34-65	1.6	3.4	251	176	127	42
	575-5755	70-80	1.6	3.4	256	186	137	42
SXD-8A	1043-10438	41-95	3.1	6.3	308	211	154	53
	1123-11233	100-105	3.1	6.3	308	220	163	53
SXD-14A	1852-18521	50-117	4.8	11.4	378	252	200	64
SXD-30A	4188-41882	110-155	10.5	20.5	460	300	253	85
	4459-44593	160-175	10.5	20.5	460	313	265	85

## REDUCERS

Reducer work together with the SXD Ratchet link. One single Ratchet link is suitable for many bolts sizes. (by the reducer, please contact SHINGARE engineer)



## SPECIFICATION

SXD-2				SXD-4				SXD-8				SXD-14				SXD-32			
Type	R	A	Max Torque	Type	R	A	Max Torque	Type	R	A	Max Torque	Type	R	A	Max Torque	Type	R	A	Max Torque
SXD-2-19	27	16	2328	SXD-4-34	36	16	2510	SXD-8-41	46	22	10941	SXD-14-50	60	31	18521	SXD-32-85	78	28	41882
SXD-2-22	27	14	2328	SXD-4-36	36	15	2510	SXD-8-46	46	19	10941	SXD-14-55	60	28	18521	SXD-32-90	78	28	41882
SXD-2-27	27	11	2328	SXD-4-41	39	15	5021	SXD-8-50	46	17	10941	SXD-14-60	60	25	18521	SXD-32-95	83	28	41882
SXD-2-30	29	12	2328	SXD-4-46	42	15	5858	SXD-8-55	50	18	10941	SXD-14-65	60	22	18521	SXD-32-100	83	25	41882
SXD-2-32	29	11	2328	SXD-4-50	44	15	5858	SXD-8-60	52	17	10941	SXD-14-70	60	19	18521	SXD-32-105	89	28	41882
SXD-2-34	31	11	2328	SXD-4-55	46	14	5858	SXD-8-65	55	17	10941	SXD-14-75	63	19	18521	SXD-32-110	89	25	41882
SXD-2-36	31	10	2328	SXD-4-60	50	15	5858	SXD-8-70	58	17	10941	SXD-14-80	66	19	18521	SXD-32-115	95	28	41882
SXD-2-41	34	10	2328	SXD-4-65	53	15	5858	SXD-8-75	60	17	10941	SXD-14-85	69	19	18521	SXD-32-117	95	27	41882
SXD-2-46	37	10	2328	SXD-4-70	56	15	6474	SXD-8-80	63	16	10941	SXD-14-90	72	20	18521	SXD-32-120	95	25	41882
SXD-2-50	40	11	2328	SXD-4-75	59	15	6474	SXD-8-85	66	16	10941	SXD-14-95	74	19	18521	SXD-32-125	101	29	41882
SXD-2-55	43	11	2328	SXD-4-80	61	15	6474	SXD-8-90	69	17	10941	SXD-14-100	77	19	18521	SXD-32-130	101	26	41882
SXD-2-60	46	11	2414	-	-	-	-	SXD-8-95	71	16	10941	SXD-14-105	80	19	18521	SXD-32-135	104	26	41882
-	-	-	-	-	-	-	-	SXD-8-100	75	17	11774	SXD-14-110	83	19	18521	SXD-32-140	110	29	41882
-	-	-	-	-	-	-	-	SXD-8-105	78	17	11774	SXD-14-115	87	20	18521	SXD-32-145	110	26	41882
-	-	-	-	-	-	-	-	-	-	-	-	SXD-14-117	87	19	18521	SXD-32-150	116	29	41882
-	-	-	-	-	-	-	-	-	-	-	-	-	-	-	-	SXD-32-155	116	26	41882
-	-	-	-	-	-	-	-	-	-	-	-	-	-	-	-	SXD-32-160	128	36	44593
-	-	-	-	-	-	-	-	-	-	-	-	-	-	-	-	SXD-32-165	128	33	44593
-	-	-	-	-	-	-	-	-	-	-	-	-	-	-	-	SXD-32-170	128	30	44593
-	-	-	-	-	-	-	-	-	-	-	-	-	-	-	-	SXD-32-175	128	27	44593

## ACCESSORIES

Reaction Pad	
Extending Reaction Arm	

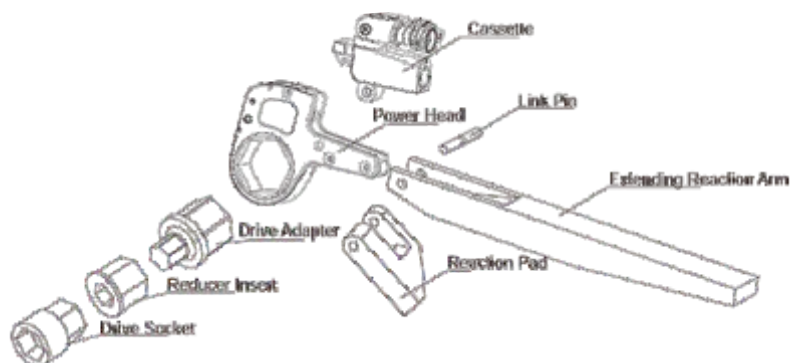

## BXD HYDRAULIC TORQUE WRENCHES – LOW PROFILE HEXAGON

### TECHNICAL SPECIFICATION:

Torque Capacity up to 48327 Nm  
 Torque Accuracy of +/- 3 %  
 Working Pressure 700 bar



### FEATURES:

- Lightweight
- Output torque capacities from 232 to 44593 Nm
- Low profile design for direct in-line reaction
- Narrow cassette head design makes it ideal for limited access applications
- Ratchet head can be easily changed by simply withdrawing/inserting a single pin
- Imperial ratchet heads available with across flat (AF sizes) sizes from 1 1/16" to 6 7/8"
- Metric ratchet heads available with across flat (AF sizes) sizes from 24 to 175 mm
- Fitted with 360°x 180° swivel with quick release couplings for easy positioning of hydraulic hoses

## ACCESSORIES

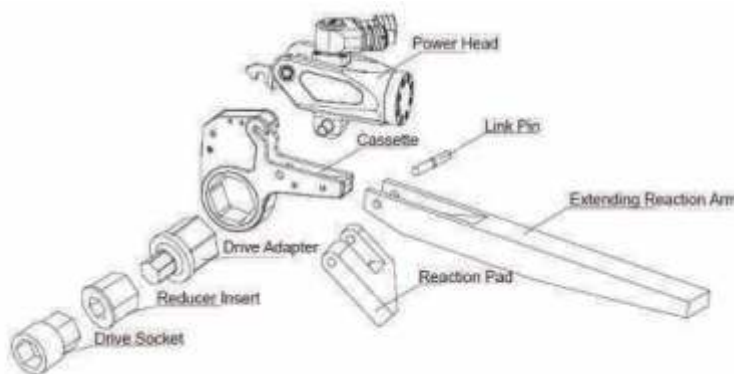

MODEL NO.	TORQUE NM	NUT SIZES IN MM	POWER HEAD WEIGHT IN KGS	LINK / CASSATTE WEIGHT IN KGS
BXD-2	232-2328	19-55	1	1.6
	241-2414	60	1	1.7
BXD-4	585-2510	34-36	-	-
	585-5021	41	2	4.4
	585-5858	46-65	2	4.6
	647-6474	70-80	-	-
BXD-8	1000-11000	41-95	3.0	8.2
	1120-12100	100-105	3.5	9
BXD-14	1852-18521	50-117	5.5	11.6
BXD-32	4188-41882	110-155	11.4	29
	4459-44593	160-175	11.4	30

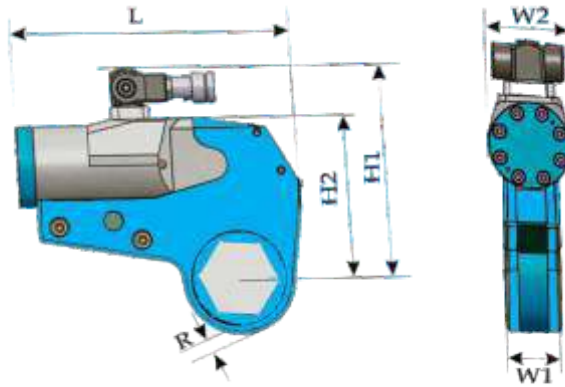

Dimension Model No.	L	H1	H2	W1	W1
BXD-2	196.4 196.4	125.9 128.5	102.3 105	32 32	51 51
BXD-4	245 246	177 187	135.7 145.7	42 42	66 66
BXD-8	300 301	207 216	169 178	53 53	83 83
BXD-14	361	239	204	64	99
BXD-32	430 441	303 315	272 285	85 85	131 131

## BXD SERIES HEX / RATCHET LINKS

BXD-2				BXD-4				BXD-8				BXD-14				BXD-32			
Type	R	A	Max Torque	Type	R	A	Max Torque	Type	R	A	Max Torque	Type	R	A	Max Torque	Type	R	A	Max Torque
BXD-2-19	27	16	2328	BXD-4-34	36	16	2510	BXD-8-41	46	22	10941	BXD-14-50	60	31	18521	BXD-32-85	78	28	41882
BXD-2-22	27	14	2328	BXD-4-36	36	15	2510	BXD-8-46	46	19	10941	BXD-14-55	60	28	18521	BXD-32-90	78	28	41882
BXD-2-27	27	11	2328	BXD-4-41	39	15	5021	BXD-8-50	46	17	10941	BXD-14-60	60	25	18521	BXD-32-95	83	28	41882
BXD-2-30	29	12	2328	BXD-4-46	42	15	5858	BXD-8-55	50	18	10941	BXD-14-65	60	22	18521	BXD-32-100	83	25	41882
BXD-2-32	29	11	2328	BXD-4-50	44	15	5858	BXD-8-60	52	17	10941	BXD-14-70	60	19	18521	BXD-32-105	89	28	41882
BXD-2-34	31	11	2328	BXD-4-55	46	14	5858	BXD-8-65	55	17	10941	BXD-14-75	63	19	18521	BXD-32-110	89	25	41882
BXD-2-36	31	10	2328	BXD-4-60	50	15	5858	BXD-8-70	58	17	10941	BXD-14-80	66	19	18521	BXD-32-115	95	28	41882
BXD-2-41	34	10	2328	BXD-4-65	53	15	5858	BXD-8-75	60	17	10941	BXD-14-85	69	19	18521	BXD-32-117	95	27	41882
BXD-2-46	37	10	2328	BXD-4-70	56	15	6474	BXD-8-80	63	16	10941	BXD-14-90	72	20	18521	BXD-32-120	95	25	41882
BXD-2-50	40	11	2328	BXD-4-75	59	15	6474	BXD-8-85	66	16	10941	BXD-14-95	74	19	18521	BXD-32-125	101	29	41882
BXD-2-55	43	11	2328	BXD-4-80	61	15	6474	BXD-8-90	69	17	10941	BXD-14-100	77	19	18521	BXD-32-130	101	26	41882
BXD-2-60	46	11	2414	-	-	-	-	BXD-8-95	71	16	10941	BXD-14-105	80	19	18521	BXD-32-135	104	26	41882
-	-	-	-	-	-	-	-	BXD-8-100	75	17	11774	BXD-14-110	83	19	18521	BXD-32-140	110	29	41882
-	-	-	-	-	-	-	-	BXD-8-105	78	17	11774	BXD-14-115	87	20	18521	BXD-32-145	110	26	41882
-	-	-	-	-	-	-	-	-	-	-	-	BXD-14-117	87	19	18521	BXD-32-150	116	29	41882
-	-	-	-	-	-	-	-	-	-	-	-	-	-	-	-	BXD-32-155	116	26	41882
-	-	-	-	-	-	-	-	-	-	-	-	-	-	-	-	BXD-32-160	128	36	44593
-	-	-	-	-	-	-	-	-	-	-	-	-	-	-	-	BXD-32-165	128	33	44593
-	-	-	-	-	-	-	-	-	-	-	-	-	-	-	-	BXD-32-170	128	30	44593
-	-	-	-	-	-	-	-	-	-	-	-	-	-	-	-	BXD-32-175	128	27	44593

# Proudly Associated With...



## SHINGARE INDUSTRIES PVT. LTD.

Formerly known as Bharatiya Industries

- ✦ Manufacturer & Exporter of Tube Cleaners, Flexible Shafts, Tube Tools, Impact Sockets, Bolting Tools, Pipe Cold Cutting and Beveling Machines, Torque Tools, Grinding Tools, Tapping Tools, Hydraulic Torque Wrench, Electric Torque Wrench, Manual Torque Wrench & Torque Multiplier
- 📍 **Factory Add:** A-48 B Osiya Mataji Compound, Village Kalher, Retibunder Road, Tal. Bhiwandi, Dist. Thane - 421302, Maharashtra.
- 📍 **Head Off:** A-104, 1st Floor, Eastern Business District (Magnet/Neptune Mall), L.B.S. Marg, Bhandup (west), Mumbai - 40078.
- ☎ +91 77188 96512 | + 91 90290 05461 ✉ bharatflex@yahoo.com | spradip@tubecleaner.co.in
- 🌐 www.shingare.com | www.tubecleaner.co.in